

Autoadapt Carolift® 90

A fixed wheelchair hoist with both powered lift and swivel.



The Carolift 90 is a wheelchair hoist designed to lift mobility devices weighing up to 90 kg into the boot of a vehicle. Swivel and lift is operated via a hand held control.

To achieve a perfect fit the Carolift 90 can be cut in both height and length upon installation. For vehicles with a sloping boot door the hoist can be folded down in between uses.

Quick facts

- Powered lift and swivel
- Foldable
- Height and length can be adjusted by cutting
- Flocked surface treatment provides pleasant grip in both hot and cold weather
- Suitable for both left and right side installations

Specifications

POWER SUPPLY 12 V
 LIFT CAPACITY 90 kg

To guarantee your safety Autoadapt products are designed and tested according to current directives and standards.

NOTE! A universal mounting bracket is included. The docking device is ordered separately.





Autoadapt Carolift® 90

Dimensions and models

Universal mounting bracket is included.
Requires a docking device to lift a wheelchair.
Docking devices are available separately.

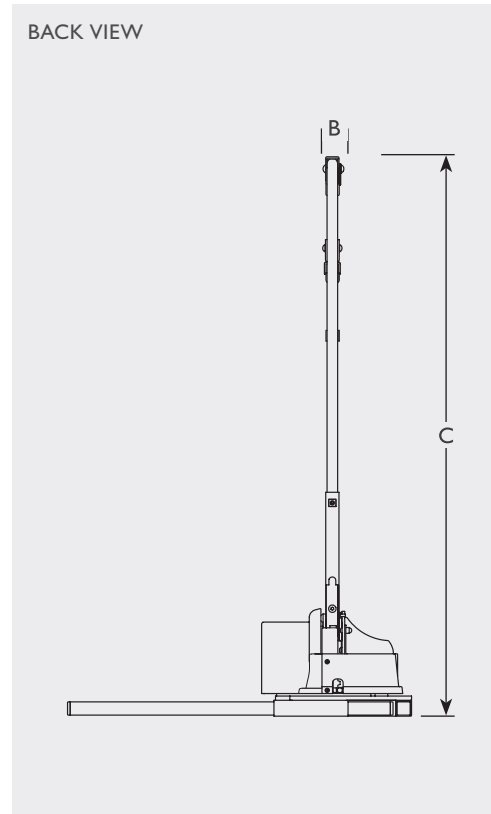
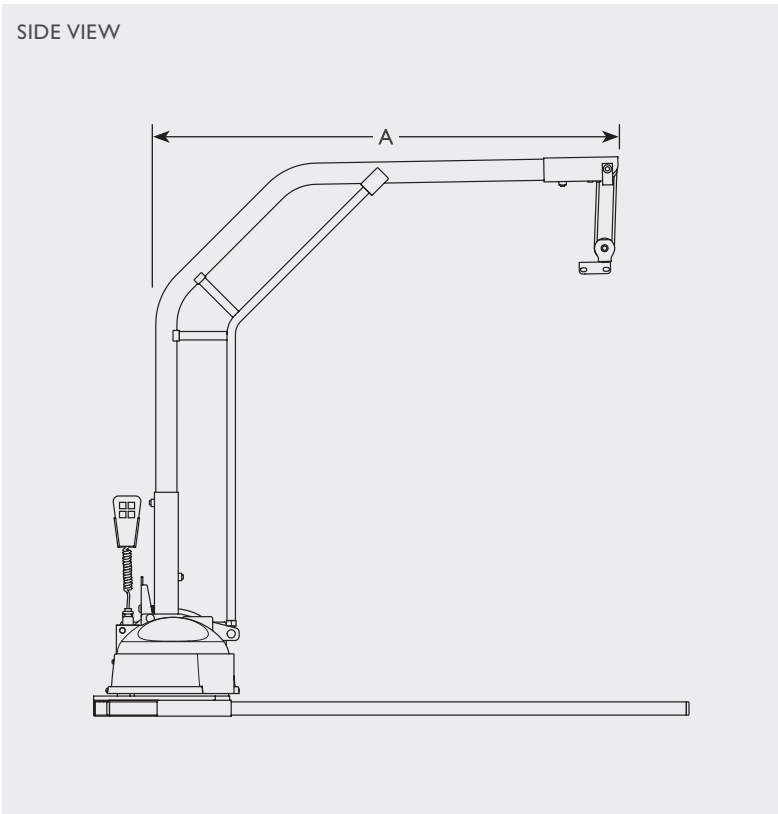

Carolift 90		Length	Width	Height	Swivel range	Folded length	Folded height	Lift capacity	Unit weight
		A	B	C					
100297	Carolift 90	80-109*	4	80-106**	0-186°	141	58	90	15

All weights and dimensions are given in kilograms and centimetres, and for reference only. *Cut to desired length during installation. **Cut to desired height during installation.