



KwikEE brand power steps have been the favorite of RVers for more than 40 years! KwikEE steps are versatile, durable and time tested. Each 750-pound-capacity step is made in America and features air pressed rivets in the pivot points instead of bolts for long-term strength. KwikEE steps automatically extend and retract when the door is opened or closed and also feature a reflective strip for added safety.

The Revolution Step by KwikEE

- Extra sturdy
- 30 percent lighter than competing power steps
- Single and double step configurations



Only weighs 24 pounds



part no.	description
369449	Revolution Series. Complete Double Step (Reference OEM P/N 9010000464)
369592	Revolution Series. Complete Single Step (Reference OEM P/N 9010000465)
380073	Revolution Step Motor (Reference PGK P/N 1510000147)
363980	Revolution Step Control (Reference PGK P/N 1510000172)

Original KwikEE Step - Single Tread

<p>Series 26 Rise: 5" Run: 8.5" Bolt pattern: 7.5" x 20.5"</p>	<p>Series 28 Rise: 7" Run: 10" Bolt pattern: 6.5" x 22"</p>	<p>Series 30 Rise: 7.5" Run: 16.75" Bolt pattern: 6" x 31"</p>	<p>Series 33 Rise: 8" Run: 16.75" Bolt pattern: 6" x 23.5"</p>
		*Available with brackets for van applications	
<p>Series 35 Rise: 5" Run: 10.75" Bolt pattern: 8" x 22"</p>	<p>Series 36 Rise: 5" Run: 10.75" Bolt pattern: 8" x 26"</p>	<p>Series 38 Rise: 4" Run: 10.75" Bolt pattern: 8" x 22"</p>	<p>Series 39 Rise: 8" Run: 10" Bolt pattern: 7.5" x 20.5"</p>

Single Tread Step

step series	part no.	step control	tread size	switch kit	rise	run
26 Series	3711361	No	23.5"	371010	5"	8.5"
26 Series	3711363	Yes	23.5"	369311	5"	8.5"
28 Series	3747451	No	23.75"	371010	7"	10"
28 Series	3747453	Yes	23.75"	369311	7"	10"
30 Series	369411	No	36"	None	7.5"	16.75"
30 Series	3694112	Yes	36"	None	7.5"	16.75"
33 Series	3722662	No	28.13"	371010	8"	16.75"
33 Series	3722661	Yes	28.13"	369311	8"	16.75"
35 Series	3691462	No	24"	371010	4"	11"
35 Series	3691461	Yes	30"	369311	4"	11"
36 Series	3756271	Yes	30"	369311	5"	10.75"
38 Series	372338	No	24"	371010	4"	14"
38 Series	3723383	Yes	24"	369311	4"	14"
39 Series	3724741	No	23.75"	371010	7"	10"
39 Series	3724742	Yes	23.75"	369311	7"	10"

**All Steps listed come with appropriate motor. **Rise/Run is estimated. See diagrams for exact dimensions.
*36 Series Step dimensions have changed. Verify sizing by specific part number.

QUICK FACTS

- Supports up to 750 pounds
- Heavy-gauge steel, powder coated for a long-lasting finish
- 12v DC motor with sealed connections
- Solid steel 3/4" drive rods and stainless steel bushings
- Electric steps available with basic power switch or Logic Control Unit sensor mode operation



Only weighs 36 pounds

The Original KwikEE Step - Double & Triple Tread

Series 32

Rise: 7" Run: 9"
Bolt pattern: 8" x 22"

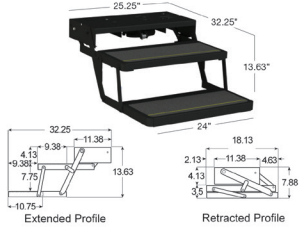

Series 34

Rise: 7" Run: 9"
Bolt pattern: 8" x 26"

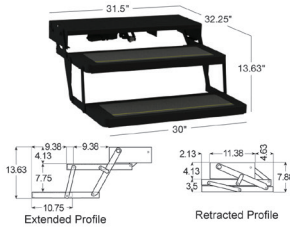

Series 40

Rise: 8" Run: 9"
Bolt pattern: 8" x 26"

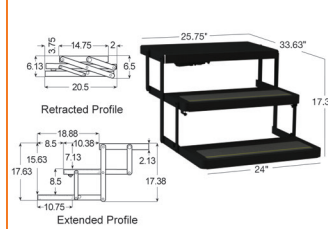

Series 42

Rise: 6" Run: 9"
Bolt pattern: 18" x 29"

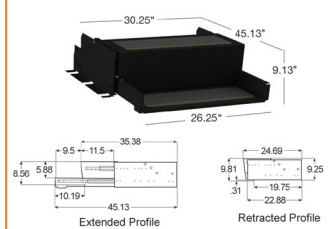

Series 23

Rise: 8" Run: 8"
Bolt pattern: 9" x 25.25"

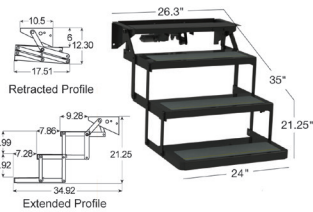

Series 24

Rise: 8" Run: 9"
Bolt pattern: 8" x 26"

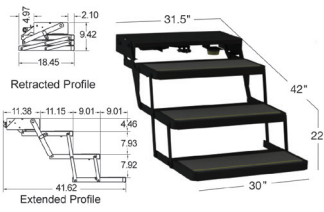

Series 25

8" Drop
Rise: 8" Run: 9"
Bolt pattern: 8" x 26"

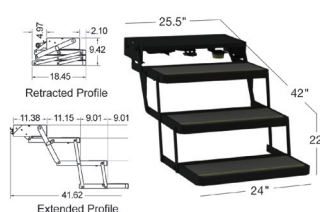

Series 25

7" Drop
Rise: 7" Run: 8"
Bolt pattern: 8" x 22"

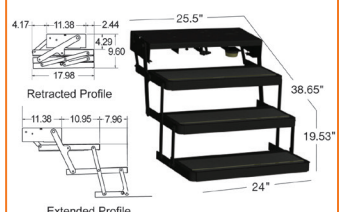

Double & Triple Tread Step

step series	part no.	step control	tread size	switch kit	rise	run
32 Series	3722617	No	24"	371010	7"	9"
32 Series	372261	Yes	24"	369311	7"	9"
34 Series	3722863	No	30"	371010	7"	9"
34 Series	3722862	Yes	30"	369311	7"	9"
40 Series	3726891	No	24"	371010	8"	10"
40 Series	3726892	Yes	24"	369311	8"	10"
Platinum	372558	Yes	24"	none	9"	11"
42 Series	372779	Yes	26.25"	none	6"	9"
23 Series	369404	No	24"	371010	8"	8"
23 Series	3694042	Yes	24"	369311	8"	8"
24 Series	375821	Yes	30"	No Switches	8"	9"
25 Series	365837	Yes	24"	8" Drop; No Switches	8"	9"
25 Series	369552	Yes	24"	7" Drop; No Switches	7"	8"
25 Series	3658373	Yes	24"	369311	8"	9"

**All Steps listed come with appropriate motor. **Rise/Run is estimated. See diagrams for exact dimensions.

QUICK FACTS

- Supports up to 750 pounds
- Heavy-gauge steel, powder coated for a long-lasting finish
- 12v DC motor with sealed connections
- Solid steel 3/4" drive rods and stainless steel bushings
- Electric steps available with basic power switch or Logic Control Unit sensor mode operation



KWIKEE® STEP CONVERSION KITS

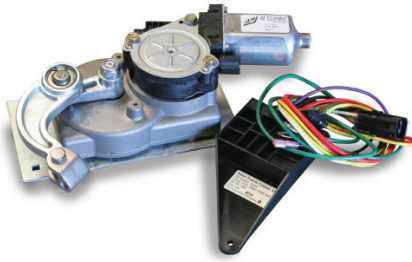

Electric Step Improvements

IMGL

Integrated Motor/Gear Box/ Linkage offers improved performance and longer life.

Improved Motor

40% more motor torque gives step a strong lock-out and solid feel.

Improved Gearbox

Fully-sealed dual ball bearing improves efficiency and requires no maintenance. Case halves seal to keep consistent alignment and protect gear from the elements.

Improved Linkage

Investment cast zinc-plated steel linkage assembly is strong and more resistant to corrosion. The brass spherical outer cage hardened ball in the linkage is stronger, wears longer and will not oblong.

Improved Control Unit Logic

The 9510 Control Unit keeps the step open when the door is open. Step can be locked in the extended position, but cannot be locked in the retracted position. Automatic ignition override makes step follow the door.

MOTOR ASSEMBLY DRAWING AND PARTS KEY NUMBERS

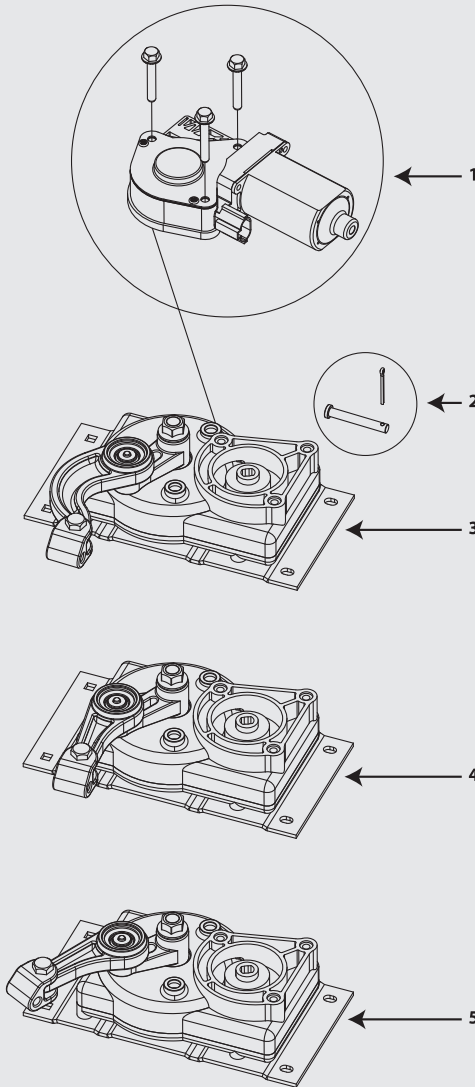

Replacement Parts Kits for Steps Series

22, 23, 30, 32, 33, 34, 35, 36, 38 and 40

parts key #	description	replacement kit part no.
1,2,3	"A" Linkage IMGL & Control Unit	379145
3	"A" Linkage Gearbox	379160
1	Step Motor Only	379147
2	Pin & Clevis Kit	379178

Replacement Parts Kits for Steps Series 28, 31, 37 and 39

parts key #	description	replacement kit part no.
1,2,4	"B" Linkage IMGL & Control Unit	379769
4	"B" Linkage Gearbox	379161
1	Step Motor Only	379147
2	Pin & Clevis Kit	379178

Replacement Parts Kits for Steps Series 26

parts key #	description	replacement kit part no.
1,2,5	"C" Linkage IMGL & Control Unit	379801
5	"C" Linkage Gearbox	379162
1	Step Motor Only	379147
2	Pin & Clevis Kit	379178

Replacement parts for older motor/control combinations are the same as for steps fitted with the IMGL and 9510 Control. IMGL and 9510 Control require a 'NORMALLY OPEN' door switch to operate correctly. Replacement switches included in kit.

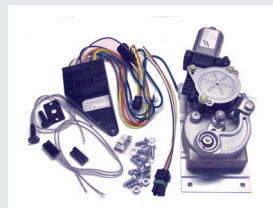

379145 for steps with 'A' linkage

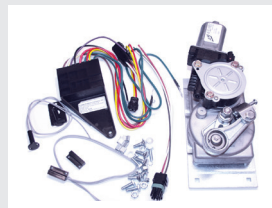

379769 for steps with 'B' linkage

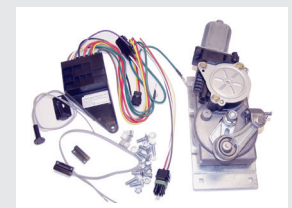

379801 for steps with 'C' linkage

MOTORIZED STEP ACCESSORIES

Kwikee Step Frame Only

If the motor control unit, light and wiring are still in working order, make your step as good as new by replacing the step frame.

**Kwikee step only*



part no.	description
3747457	28 Series Step Frame
3722618	32 Series Step Frame
3658374	25 Series Step Frame
3722864	34 Series Step Frame

Kwik Test

A time-saving diagnostic tool for RV service, the Kwik Test isolates step functions from RV power and wiring. Quickly locate the problem and replace only the parts needed.

**Kwikee step only*



part no.	description
379607	Kwik Test Tool

Glow-In-The-Dark Step Tread Replacements

Kwikee Glow-in-the-Dark Step Treads carry all the features of our original and commercial step treads, and also uses a reflective stripe and a night glow phosphorus stripe. The result is a glowing step that lights the way well into the night.

**Works with Kwikee and Coach steps*



part no.	description
379600	Glow in the Dark Step Tread Replacements

Also available in the original reflective and commercial yellow applications.

Step Maintenance

Regular use of KwikLUBE prevents step problems caused by other lubricants, reduces wear, and prevents rust. The cured KwikLUBE grease creates a film that is impervious to moisture and temperatures above 400° F.

**Works with Kwikee and Coach steps*



part no.	description
379176	Kwik Lube 11 oz. can
379177	Kwik Lube - Case of (24) 11 oz. cans